

ordering number:

**PBC-01 U784**

**professional crimping tool for  
Bel Stewart RJ45 8P8C CAT6  
shielded modular plugs**

**please read this brochure carefully  
before using the tool for the first time**



### 1. Preparing the tool for work

- ❑ With this tool **only** plugs of **appropriate type** should be used. Cable size is also very important, for different cable diameters different sub-inserts are shipped with the tool.
- ❑ Fig.1. clarifies terms "upper sub-insert", "lower sub-insert" and "cable size stripes" necessary for correct tool preparation. Using the inappropriate combination of sub-inserts and cable size (O.D.) may result with false crimp, and tool damaging for which the manufacturer cannot be held responsible.

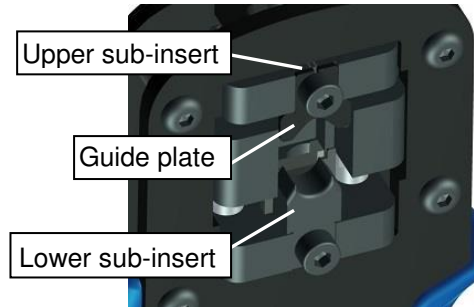

Fig.1.

- ❑ Sub inserts are easily dismounted using the 3 mm allen wrench (supplied)
- ❑ **IMPORTANT: Insert and hold allen key vertically while tightening and untightening bolt. When tightening bolt use moderate force. Excessive force can cause socket head damage.**

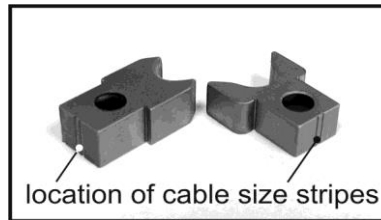

Fig.2.

- ❑ Each sub-insert, both upper and lower, is marked with stripes (Fig.2.). Both can have one, two or three stripes
- ❑ Select appropriate upper and lower sub-insert according to Table 1.

Plug Type	Cable O.D.	Upper sub-insert	Lower sub-insert
SS-39200-012	5,3-5,9 mm	I	I
SS-39200-010	6,0-6,6 mm	II	II
SS-39200-019	6,8-7,5 mm	III	III

Table 1.

### 2. Terminating procedure

- ❑ Load the plug according to plug manufacturer's instructions.
- ❑ **IMPORTANT: Prior to crimping, close the shield wings by hand. Width of shield wings shouldn't exceed 13 mm (Fig.3.)**

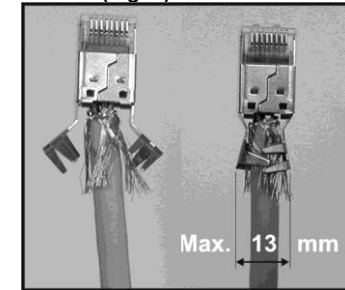

Fig.3.

- ❑ Insert the plug assembly in the tool as shown (Fig.4).



Fig.4.

- ❑ **Slowly** close tool handles completely to perform full cycle crimping. (Fig.5.)
- ❑ **IMPORTANT: Each plug should be crimped just once. Avoid double-crimp the plug due it may cause plug damage.**

**ⓘ In case the tool becomes blocked for any reason, please follow unblocking procedure (item 3.) found on the back of this brochure.**



Fig.5.

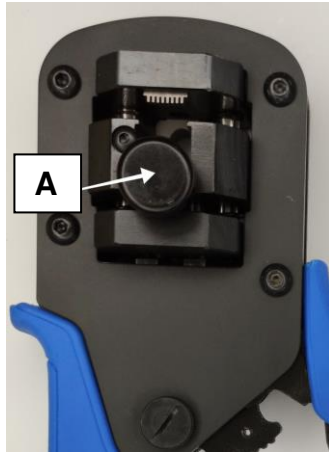

Fig. 6.

- ❑ After the full crimping cycle is done, open the tool fully in order to remove crimped plug. Press release button (A) (Fig.6.) at the back side of the tool and pull out the plug assembly. The tool is ready for next crimping cycle.

### **3. Unblocking the tool**

- ❑ **IMPORTANT:** Apply working force on the tool handles while unblocking. It will prevent hurting yourself and possible damages on the tool.
- ❑ Using a finger, push the ratchet relief (A), located inside the moving handle, (Fig. 7.) in direction as shown to unblock the tool, and remove obstruction before continuing with the work.
- ❑ With this tool only microplugs of appropriate type have to be used. Crimping microplugs of unsuitable type may result with unsatisfactory characteristics of crimped connections and eventually with damaging of the tools and is to be strictly avoided.

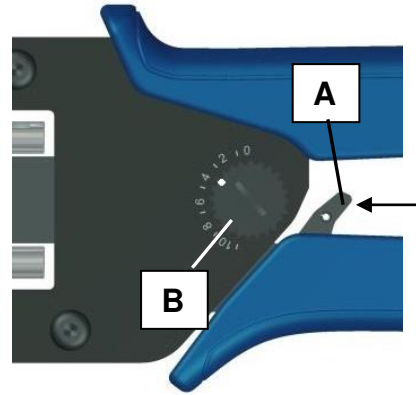

Fig.7.

### **4. Tool regulation procedure**

- ❑ After prolonged work period, tool crimping performance can change slightly due to final self-adjustment of the tools components. This handtool is equipped with eccentric axle which allows periodical adjustment of crimping force and tool recalibration to maintain correct crimp performance.
1. Loosen knurled nut (C) by turning it counter clockwise (Fig.8.)
  2. Press the nut until toothed adjustment wheel (B) is lifted so it can be rotated freely
  3. Insert screwdriver into adjustment wheel groove and rotate it to achieve desired pretension
  4. Marking dot at "0" sets lowest pretension, while dot at "10" sets highest pretension
  5. Once pretension is set push adjustment wheel back into its position and tighten knurled nut

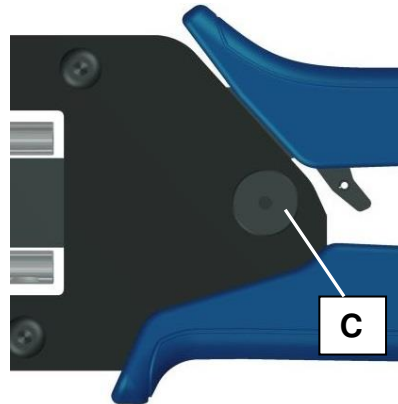

Fig.8.

### **5. Maintenance and general remarks**

- ❑ Crimping handtool PBC-01 U784 is intended to be used for crimping of Bel Stewart SS-39200-0xx series shielded modular plugs. Using this handtool for any other purpose, or for crimping of any other objects, can result in damaging the tool and the objects being crimped and prevention of its normal further functioning, for what manufacturer cannot be held responsible.
- ❑ Handtool is equipped with full cycle ratchet mechanism which with optimized leverage system within the tools make working with these tools easy and simple. In case of improper crimp, ratchet release mechanism allows you to easily open the handtool and remove obstruction before work is continued. Check unblocking procedure (item 3.).
- ❑ Tool itself also incorporates possibility of periodical adjustment of the crimping force and tool recalibration via eccentric axle. Advised is to apply certain pretension on tool in order to maintain correct crimp performance. Check recalibrating procedure (item 4.).
- ❑ For removal of dust, moisture and other contaminants usage of clean brush or soft, lint-free cloth is recommended. Do not use aggressive agents (thinner, alcohol,...) or hard objects that could damage the tool.
- ❑ Make sure that during the work bearing surfaces, shafts and pivot points are protected with thin coat of quality machine or motor oil. Do not oil excessively.
- ❑ When the tool is not in use, store it in a closed position – with handles closed. That will keep other objects from becoming stuck between crimping dies and damaging them. Keep the tool in a dry and clean area.
- ❑ Use only original spare parts.